

# Item No. F209DT

## INSTALLATION GUIDE

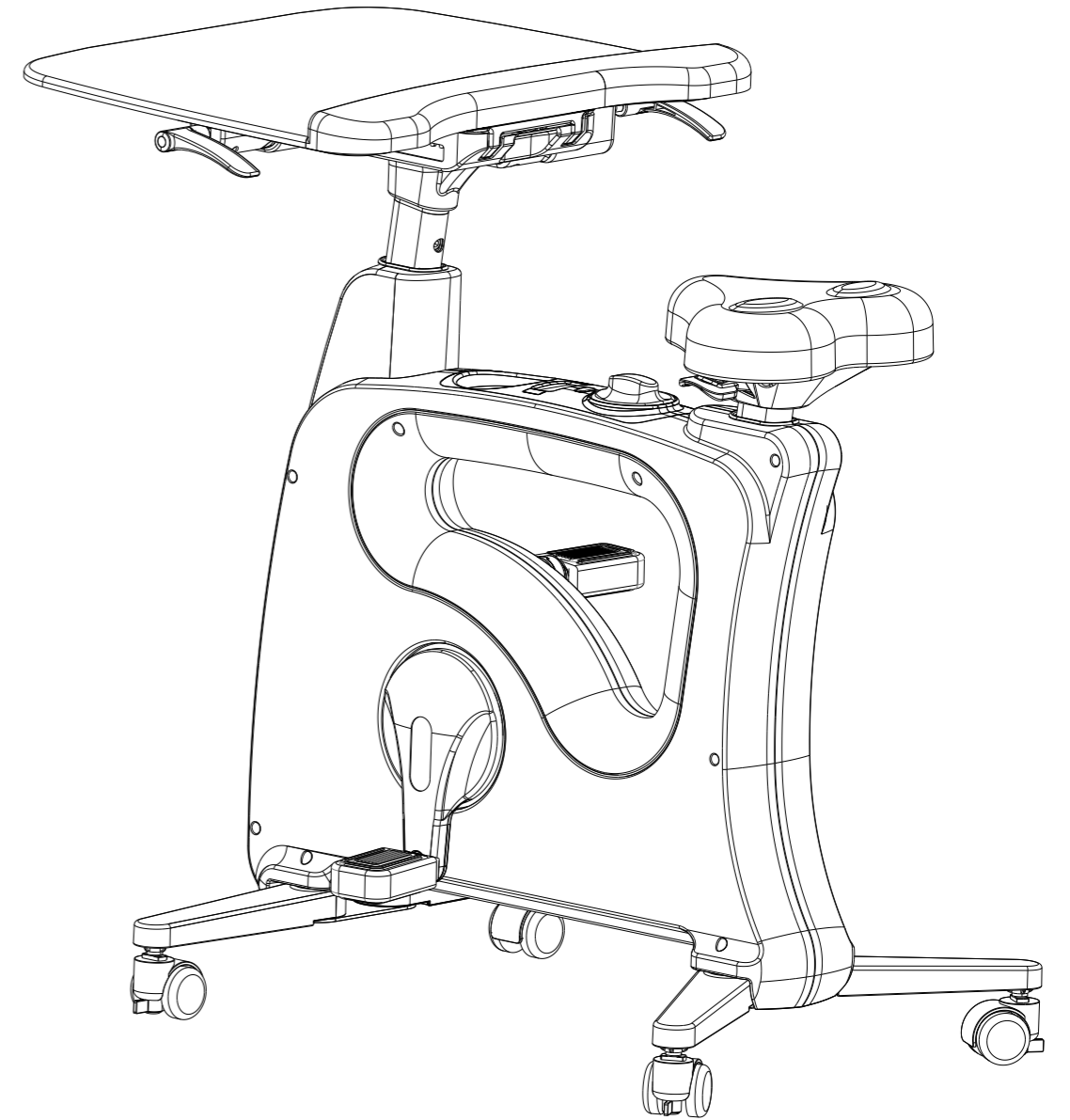

## Caution



Please read all instructions carefully before using this product. Retain this manual for future reference. The specifications of this product may vary slightly from the illustrations and are subject to change without notice.

1. Make sure you read and fully understand this instruction manual.
2. It is the user's responsibility to read and understand all potential hazards of this exercise equipment.
3. Consult a physician before you begin a new exercise program. If you should experience pain, or you feel faint, short of breath, or dizzy, stop exercising and consult a physician. Incorrect or excessive use of this machine can result in injury.
4. Your exercise bike should be operated on a stable, level surface.
5. You should mount and dismount your exercise bike carefully.
6. Loose clothing, untied shoelaces, jewelry, and towels should be kept away from the bike pedals.
7. This machine is not a toy. Keep children away from this exercise bike, especially while in use. Children should be taught to never put their fingers near any moving parts on this machine.
8. Please keep children away from this exercise bike, especially while in use. Minors are strongly recommended not to use this product, since its designed for adults.
9. Remain seated while using this bike - do not stand on pedals.
10. The maximum weight capacity of this bike is 100 kg / 220lbs.
11. The maximum load-bearing capacity of the tabletop is 25kg / 55lbs.

**Ignoring the warnings in this manual could lead to hazardous situations that might result in serious injury or death.**

## Package Included

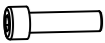
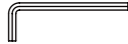
### Accessory package list

- |  |  |  |   |
|--|--|--|---|
| 1.  | 2.  | 3.  | 4.  |
| Bolt<br>M8x 35 MM<br>(1 PC)  | Hex key<br>6x6mm<br>(1 PC)   | Anti-skid pad<br>Φ89 x 2 mm<br>(1 PC)  | Pedal cover<br>(2 PC)   |

### Part list

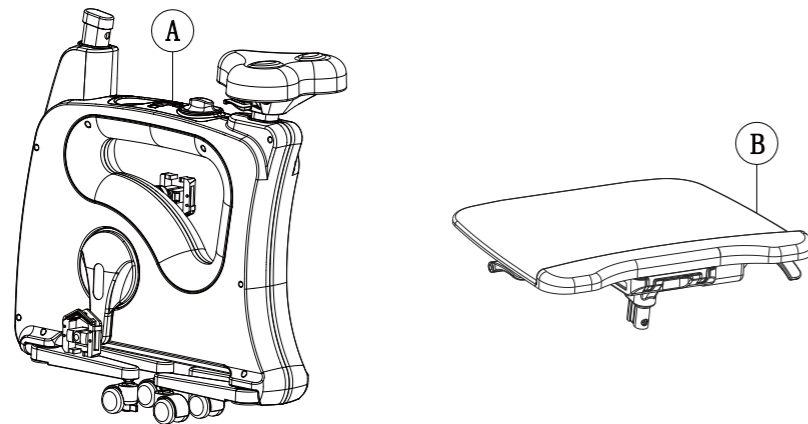

### Assembly step 1

Outspread the 4 legs of bike base (A), which will be fully extended when you hear the sound "Pa".

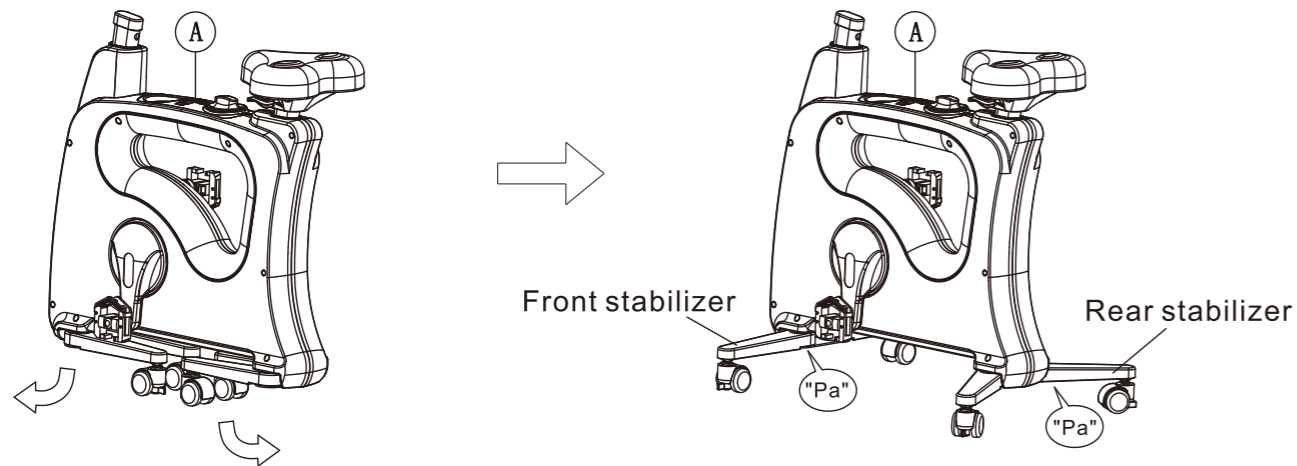

### Assembly step 2

Outspread both left and right pedals as shown in the figure until you hear a "pa" sound, and the pedals are normally opened to be horizontal.

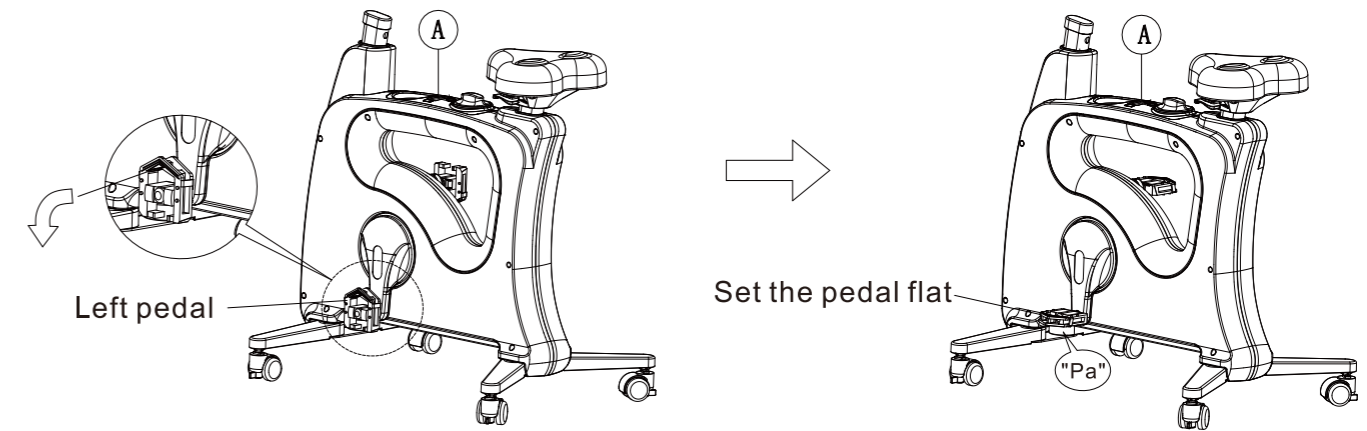

### Assembly step 3

Put the hex key (2) into the frame mounting hole completely, and press down the part exposed outside the hole, making the frame cover can be completely separated from the frame.

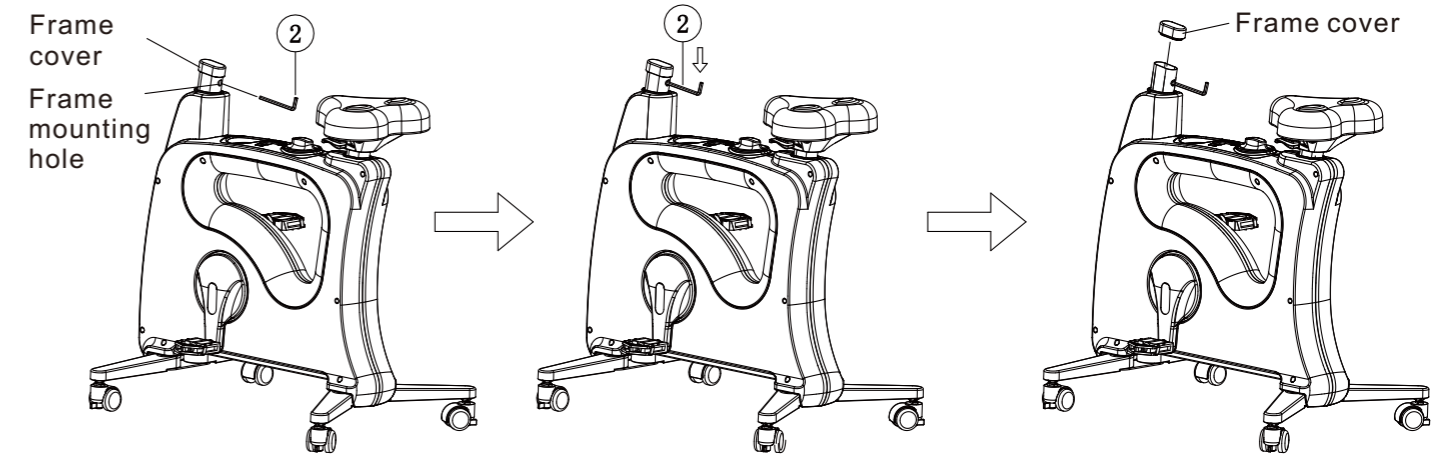

### Assembly step 4

Insert the upper assembly of the instrument tube (B) into the mounting hole of the frame assembly (A). After inserting it to the bottom, pre-screw the cylindrical head socket head cap screw (1) into the screw installation hole, and then use the hex key (2) to lock the upper section of the instrument tube assembly.

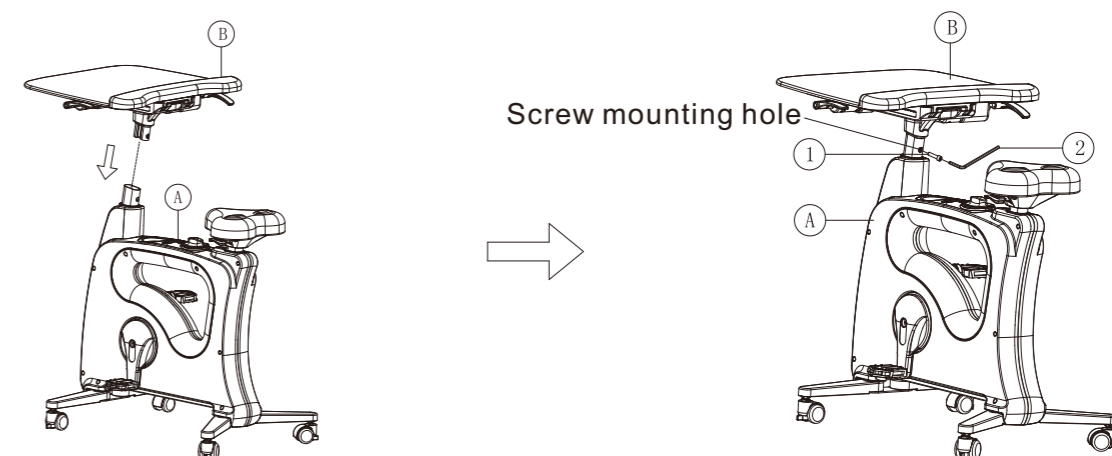

## Assembly step 5

Put the anti-skid pad (3) into the water cup groove, pay attention to the pattern side of the anti-skid pad facing up, and put the pedal protective cover (4) on the pedal.

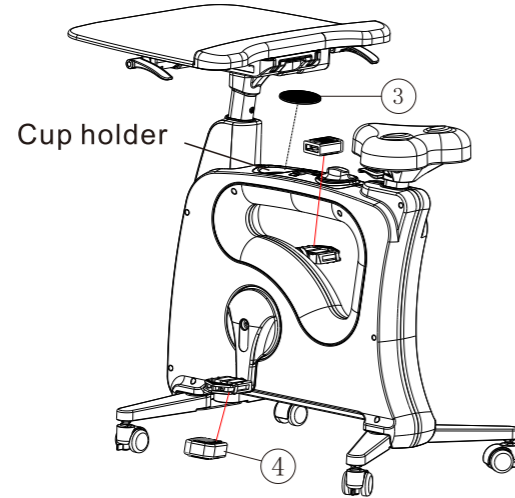

## LCD display operation guide

Press the key button to turn on the LCD display. The following activity readings will appear on the display: TMR (timer), SPD (speed), DIS (distance), CAL (calories), ODO (odometer), RPM (revolutions per minute). The LCD display will turn off when pedaling stops for more than 4 minutes. To reactivate the LCD display, start pedaling again or press the key button.

- SCAN : Readout will be changed automatically one by one per 5 seconds
- TMR : Time you exercised
- SPD : The speed when you exercise
- DIS : Distance you exercised
- CAL : Calorie you burned during your exercise
- ODO : Total distance you exercise
- RPM : Speed of the wheel

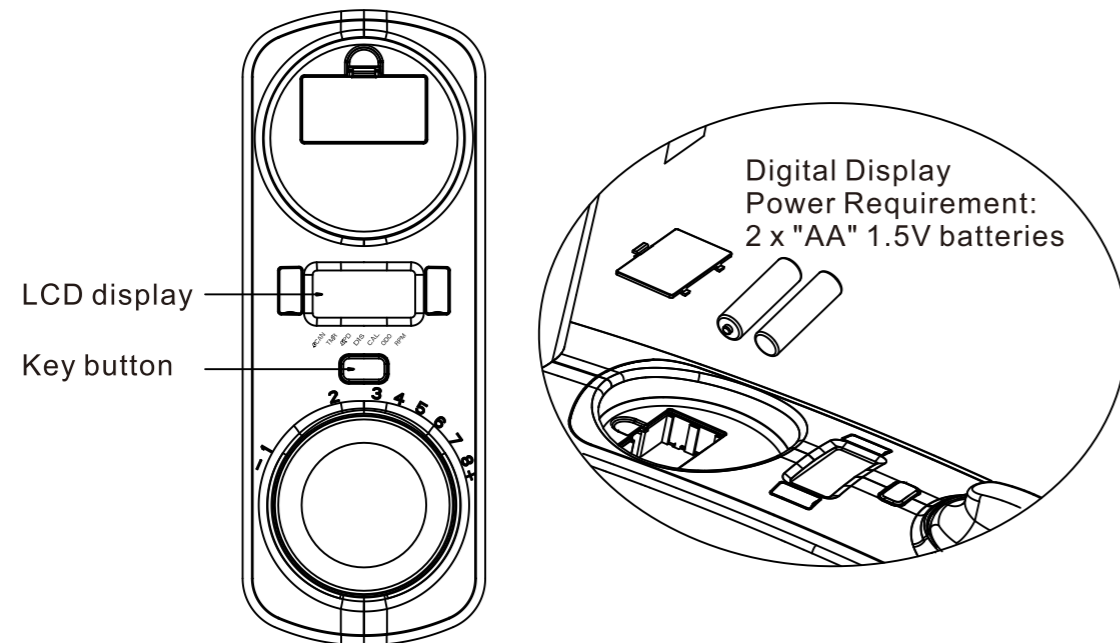

## Using the Bike

### 1. Magnetic resistance adjustment

The resistance control knob allows you to adjust the resistance level in increments from 1 to 8, with level 8 offering the most resistance. To increase the resistance level, turn the resistance control knob in the "+" direction. To reduce the resistance level, turn the knob in the "-" direction.

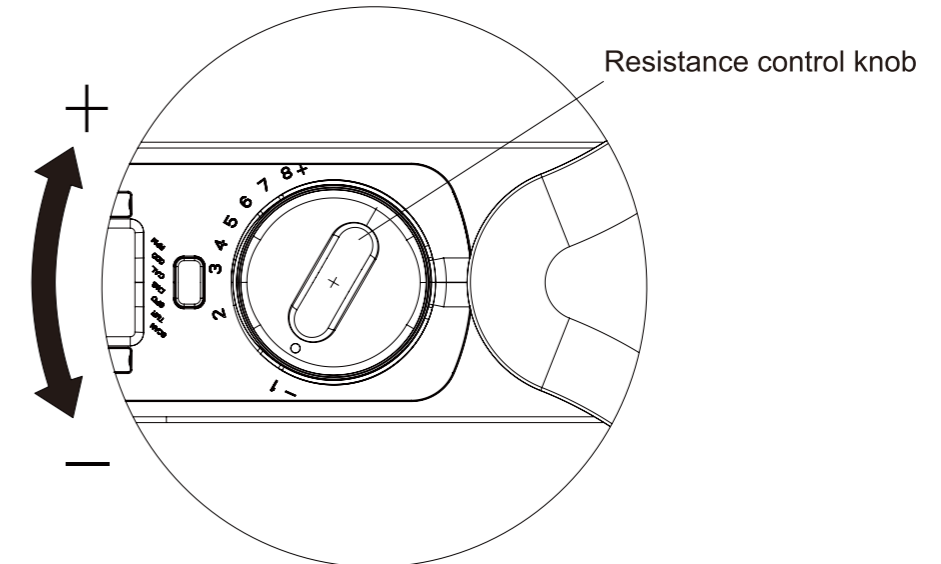

### 2. Adjusting the seat

Proper seat adjustment is essential to a comfortable ride when using the desk bike. If your leg is too straight or your foot cannot touch the pedal, you will need to move the seat down. If your leg is bent too much, you will need to move the seat up by lifting up your hip and pressing the handle bar. The seat handle bar locate below the seat (see picture).

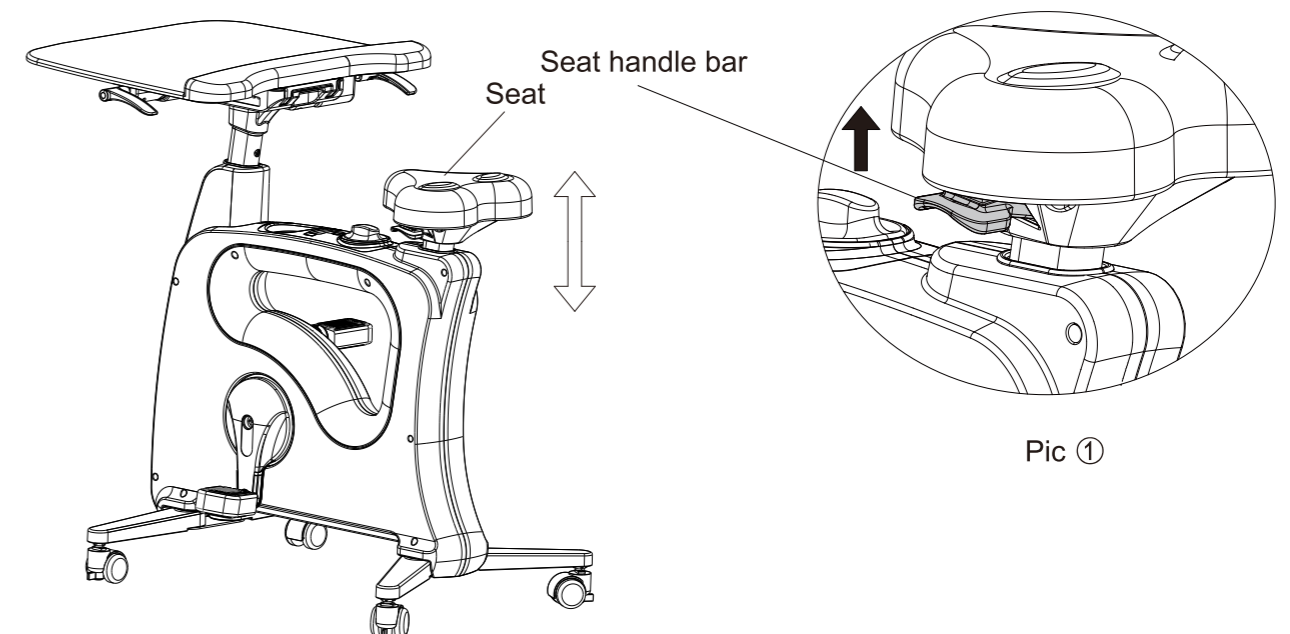



### 3. Adjusting the desktop forward/backward

To make it easy to read at a comfortable eye distance while cycling, the desktop can be adjusted forward or backward. Simply press the left handle bar below the desktop to adjust it backward and forward.



### 4. Adjusting the desktop height

Press the right handle bar to adjust the height of the desktop.

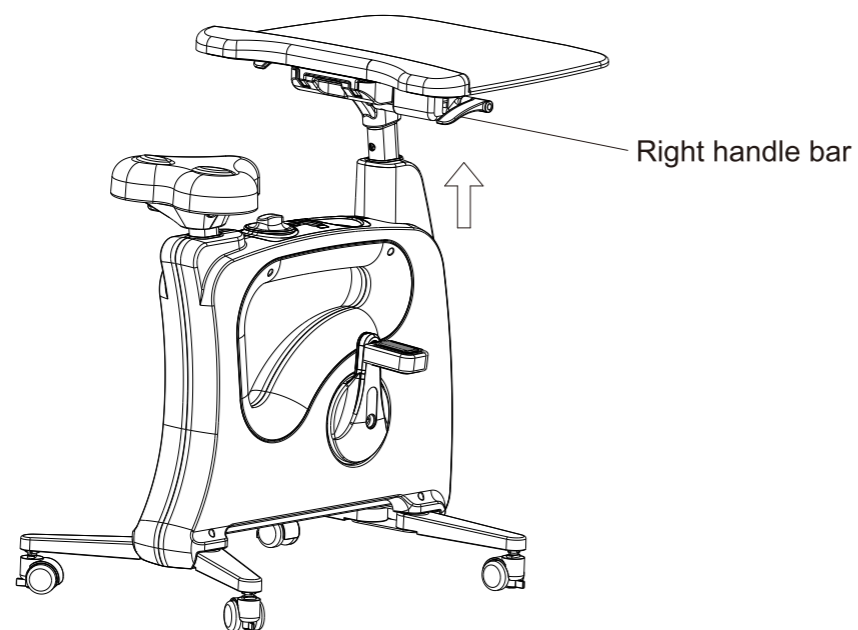

### 5. Repacking the bike for storage

If you will not be using the bike for an extended period and would like to repack it for compact storage, please do the following:

First, lower the bike onto its side, then locate the button under the legs (shown in pic ④). Use the hex key (2) to push the button. This will allow you to fold the front and rear stabilizers neatly beneath the bike.

